

WCS002

WIRELESS CHARGER STATION WITH SMARTPHONE HOLDER

OVERVIEW

With this stylish accessory, available in black colour, you can charge your smartphone and other Qi-compatible devices without the need to plug your device into a wall charger or USB port. Simply place your device directly onto the motorised pad and your phone begins to charge.

SPECIFICATIONS

| |
|---------------------------------------|
| Power Input 12-24v |
| Output 5w |
| OCP, SCP, UVP, FOD, Unload protection |
| Qi, CE, FCC, RoHs compliance |
| Transfer efficiency $\leq 80\%$ |
| Automatic lock by infrared detection |
| Electric release by touch button |
| Extra USB charging port available |

DIMENSIONS

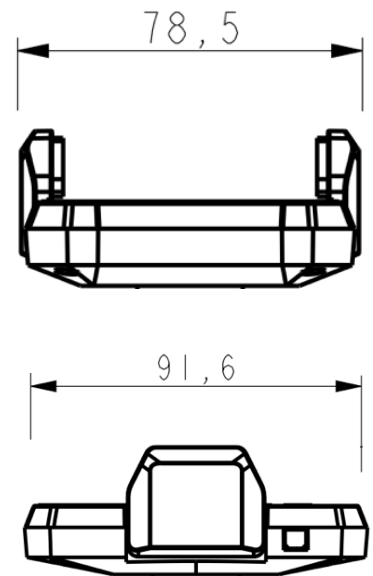

PRODUCT PARTS

wireless charging area



automatic telescopic clips

infrared sensor

touch switch

LED indicator light

USB input port

USB output port